

Karl Swanson – PCT Ebeam and Integration

Low Energy High Power X-ray for Food

HEEX facilities can handle significant throughput, but they require infrastructure and processing rigidity, unlike LEEX.

Transportation

Shielding

Penetration

Capacity

LEEX
Low-Energy,
Low-Power

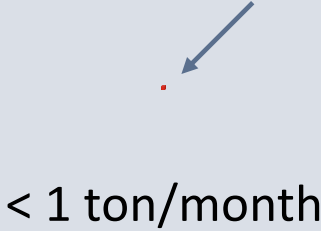
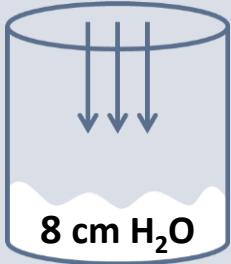
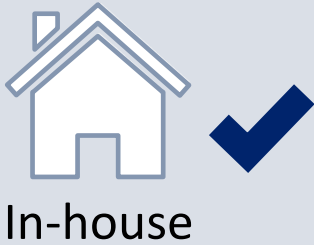

Need a medium option



HEEX
High-Energy,
High-Power

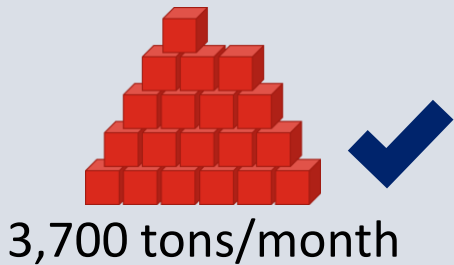
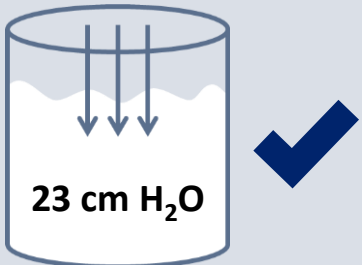
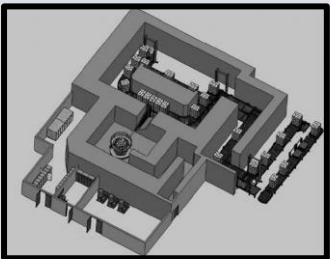

Not every product needs the penetration of gamma or HEEEX to achieve in-line bioburden reduction or sterilization.



With LEEX, it's possible to stop a greater percentage of photons in the product compared to gamma and HEEX.

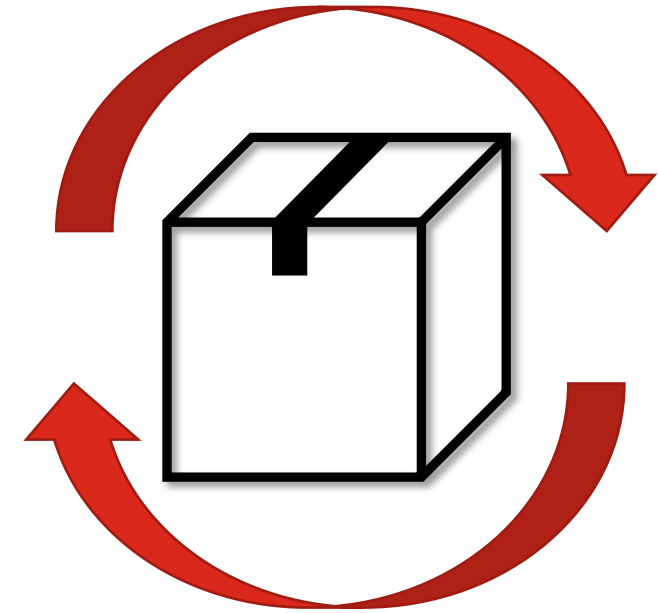
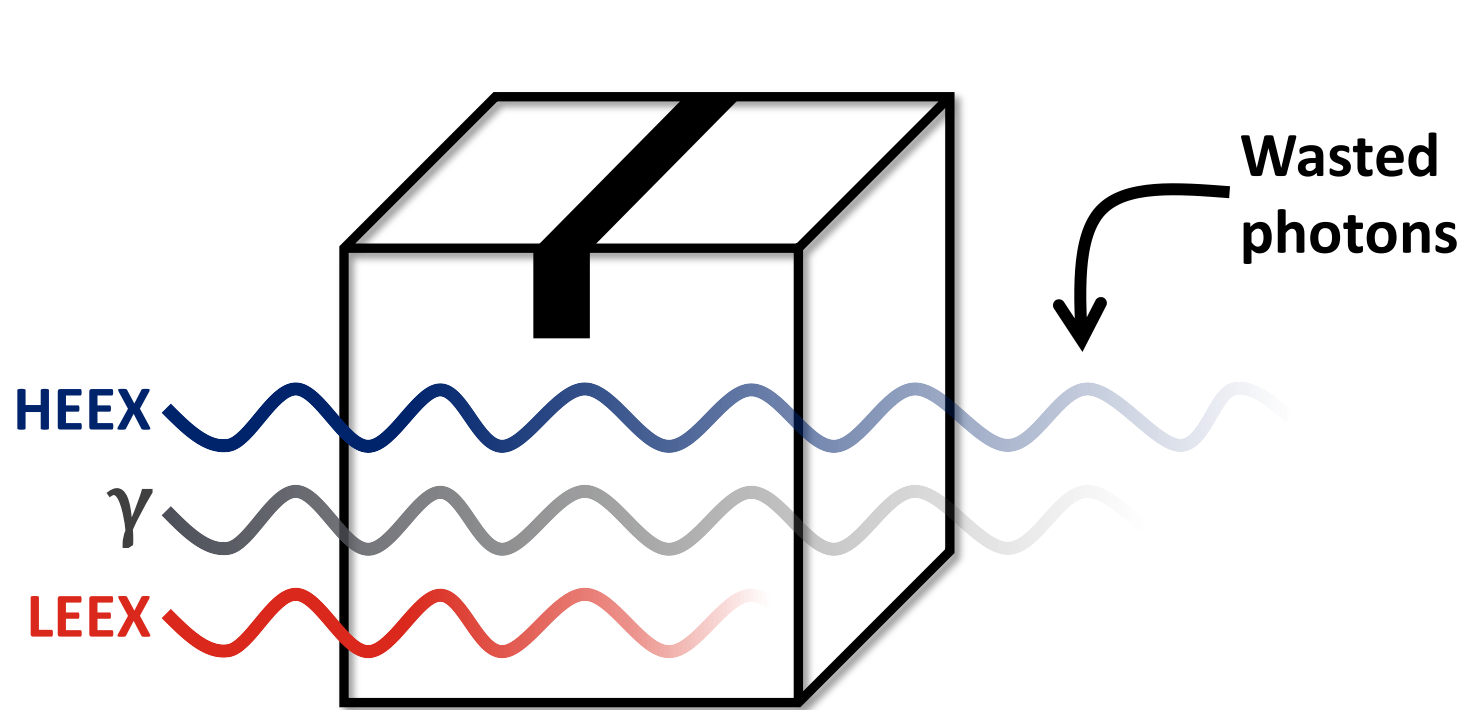

Flexibility in product handling makes it easier to manipulate the material for efficient use of the energy delivered.

HEEX facilities can handle significant throughput, but they require infrastructure and processing rigidity, unlike LEEX.

Transportation

Shielding

Penetration

Capacity

LEEX
Low-Energy,
Low-Power

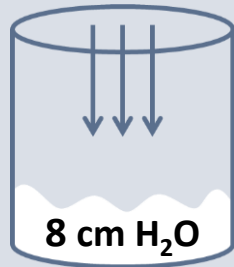
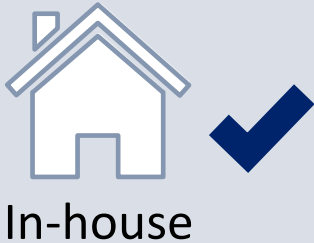

< 1 ton/month



Low Energy, High Power X-ray



HEEX
High-Energy,
High-Power

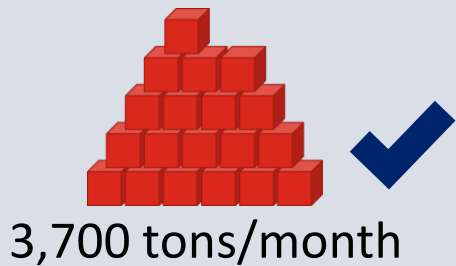
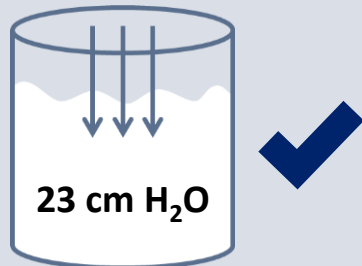
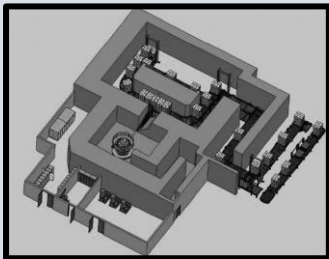

PCT and Rayfresh Foods collaborated in the development of a new kind of LEEEX system.

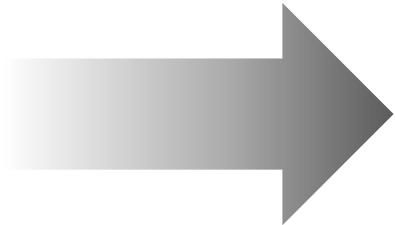

GOAL: throughput capacity sufficient for industrial processes

CHALLENGE: overcoming the low conversion efficiency of LEEEX

APPROACH: leverage the highest power capacity LEEB platform available and implement an innovative target design

RESULT:

EXE**DE**

X-RAY TECHNOLOGY BY PCT

eXede

Low-Energy, High-Power X-ray

Rated Power	Up to 600 kW / 300 keV
Exposure Area	Up to 96 in x 12 in (8 ft ²)
Shielding	Self-shielded, no bunker
Avg. Dose Rate over Exposure Area (at 600 kW)	600 Gy/minute average over top surface 240 Gy/minute average below 50 mm of water <i>Note: Actual dose to product depends on presentation, density, and dwell time</i>
Utilities	Electric power and cooling water



LEHP combines the advantages of LEEEX with increased throughput.

Transportation

Shielding

Penetration

Capacity

LEEEX
Low-Energy,
Low-Power



In-house

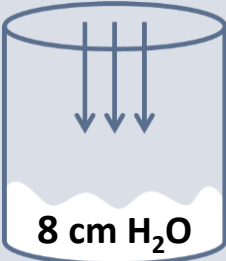

< 1 ton/month

LEHP
Low Energy,
~~HEEX~~ High Power
High-Energy,
High-Power



Required

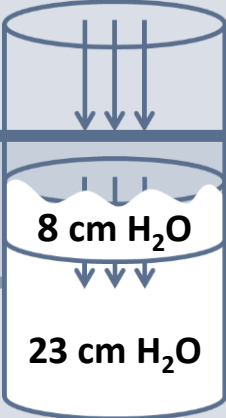

34 tons/month
3,700 tons/month

The target area on an LEHP x-ray machine can be varied in width to accommodate processing requirements.



1 ft

Target Area

4 to 8 ft



In this concept, a conveyor is used to move boxes through the x-ray system. The boxes are rotated to achieve a low DUR.

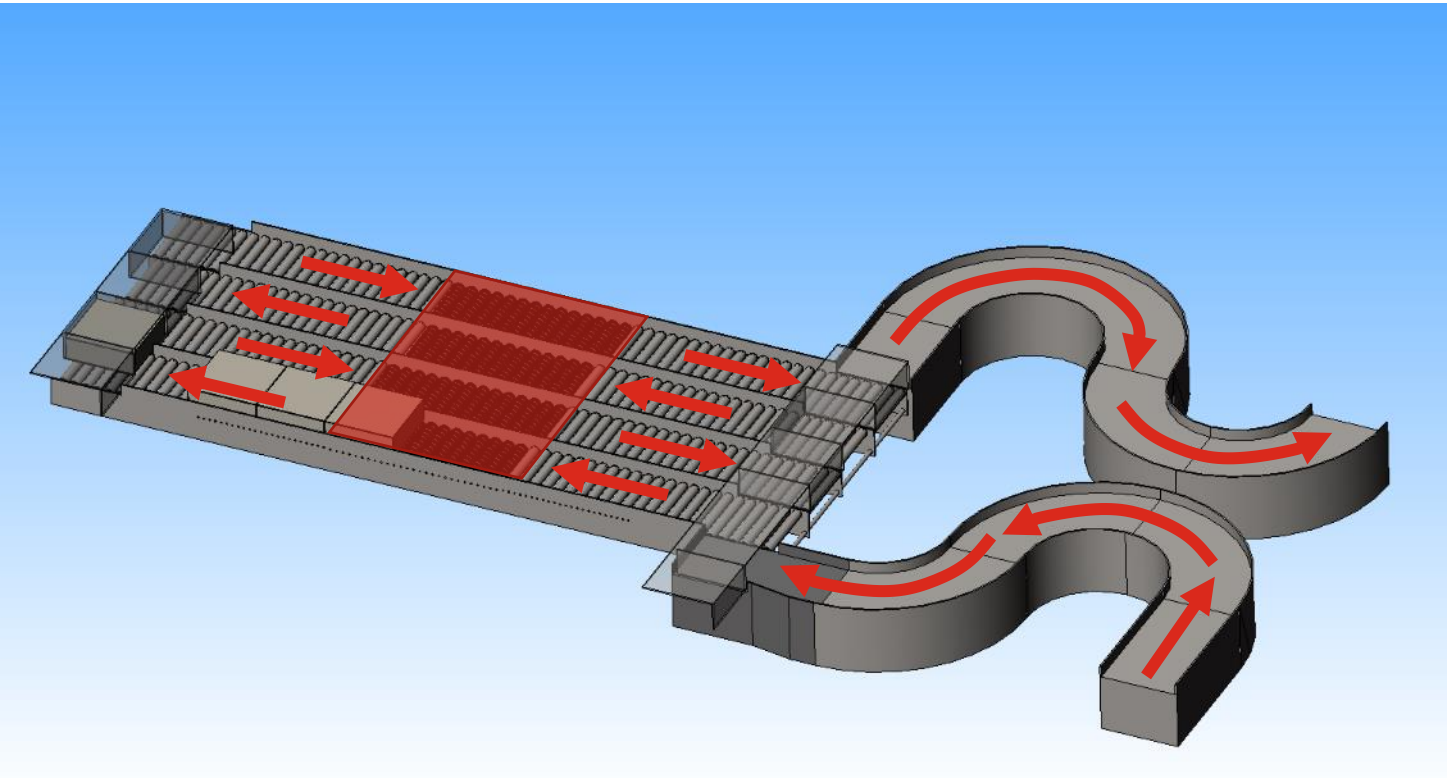
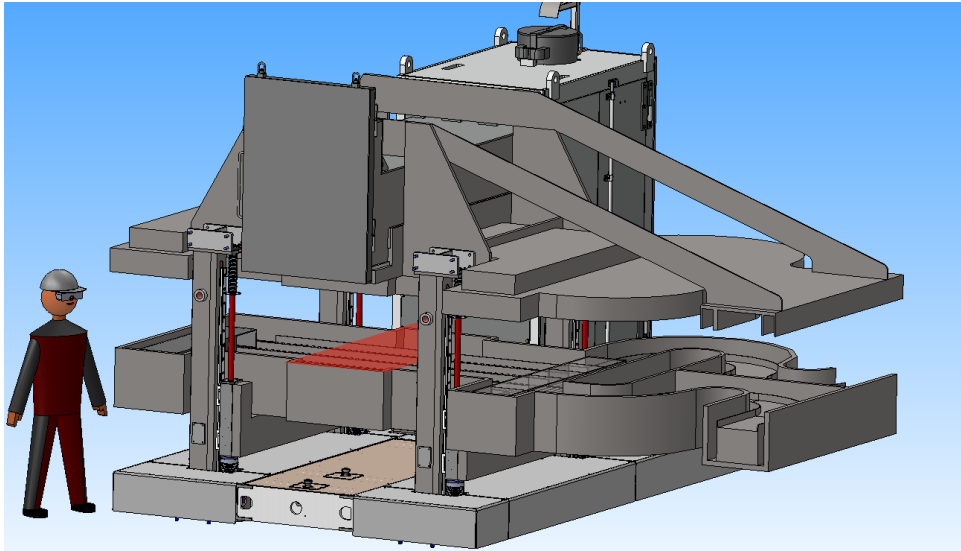

Flexibility in material handling means eXede can be customized to support a variety of applications.

- ◆ Conveyors for boxes, bags, or totes
- ◆ Pipes for liquids
- ◆ Cannisters for loose materials
- ◆ Batch *tub* for low volume, 3-D parts
- ◆ System orientation: top down, side to side, or bottom up
- ◆ Controlled atmosphere possible

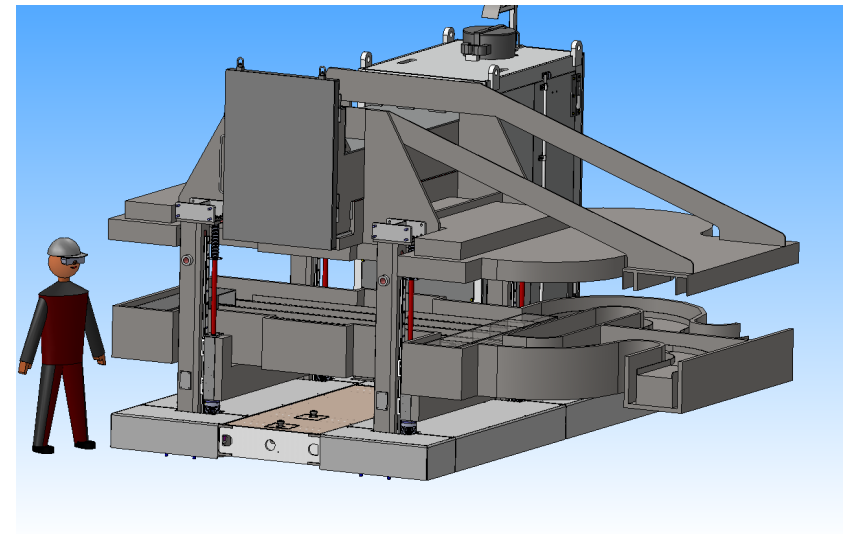
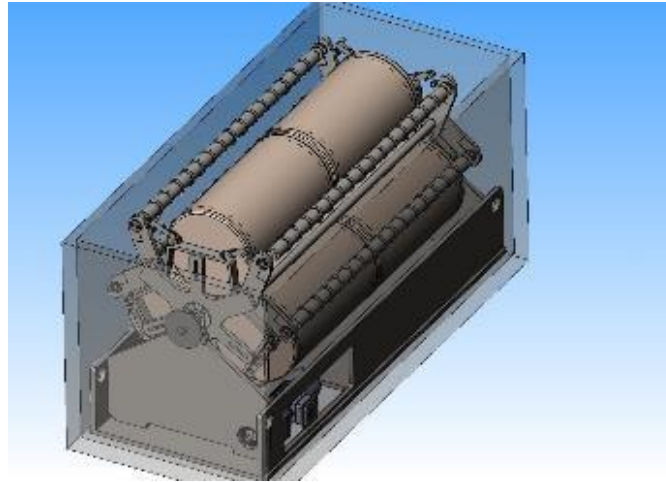

At 600 kW power and with box rotation, eXede can achieve good throughput and a low DUR.

Box size (cm x cm x cm)	Density (g/cm ³)	DUR	Throughput at 1000 Gy (kg/hour)	Throughput at 10 kGy (kg/hour)
25 x 25 x 30	0.2	1.4	270	27
15 x 25 x 30	1.0	1.7	2140	214



4 kg/hr
6 kW at 1000 Gy
(RadSource data)

500x capacity

Summary.



LEHP x-ray has **unique capabilities** for food processing.



Self-shielding facilitates in-house and in-line installations.



The higher **throughput** capacity and **flexibility** of LEHP x-ray opens the door to new processes and new uses.



PCT



EBEAM AND INTEGRATION

Get In Touch.

Karl E. Swanson
President



Phone Number

+1.563.285.7411 ext. 4446



E-mail Address

Karl.Swanson@pctebi.com



Office Address

8700 Hillandale Road
Davenport, Iowa 52806
U.S.A.

